



Instructions

For assembling container

1100 L – round lid











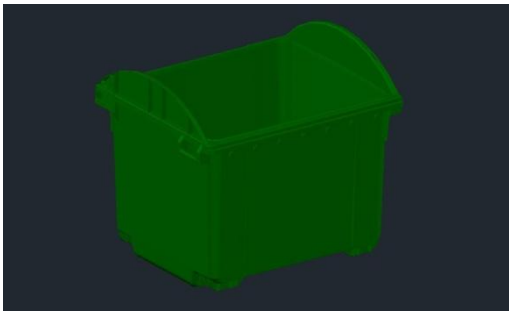
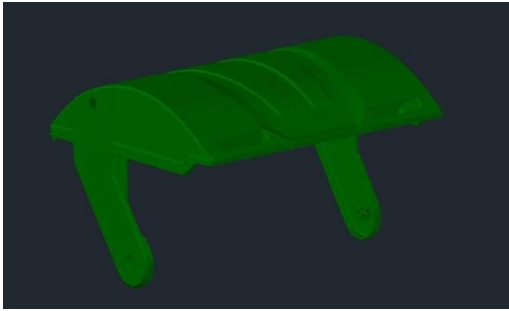

MNG PLASTIK GOGIĆ DOO
22320 Indjija, Kralja Petra I bb, Srbija
+381 (22) 561 - 674 ; +381 (22) 555-306 ; +381 (22) 552-141
office@plastikgogic.rs
www.plastikgogic.rs

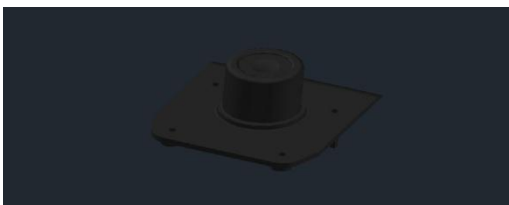
3D model

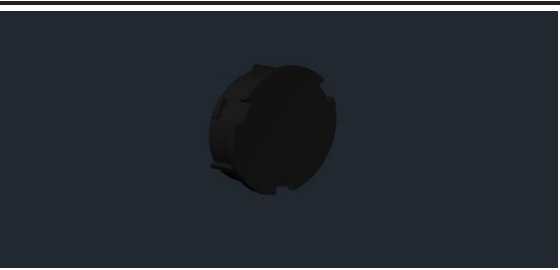
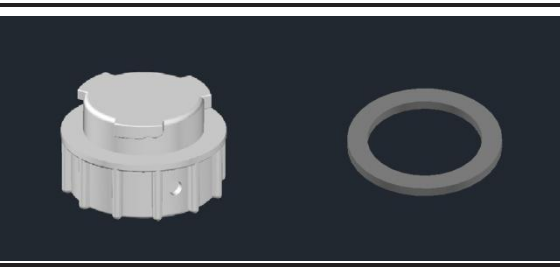
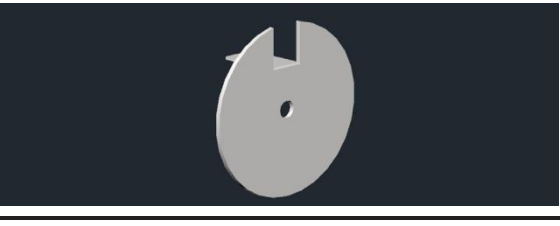

1. List of parts

<p>1. Body for round lid container</p>	
<p>2. Lid for round container</p>	
<p>3. Lifting turnnion</p>	
<p>4. Circular lid carrier</p>	
<p>5. Spring for circular carrier</p>	
<p>6. Grip for round lid</p>	
<p>7. Rubber for round lid container</p>	
<p>8. Comb for round lid container</p>	

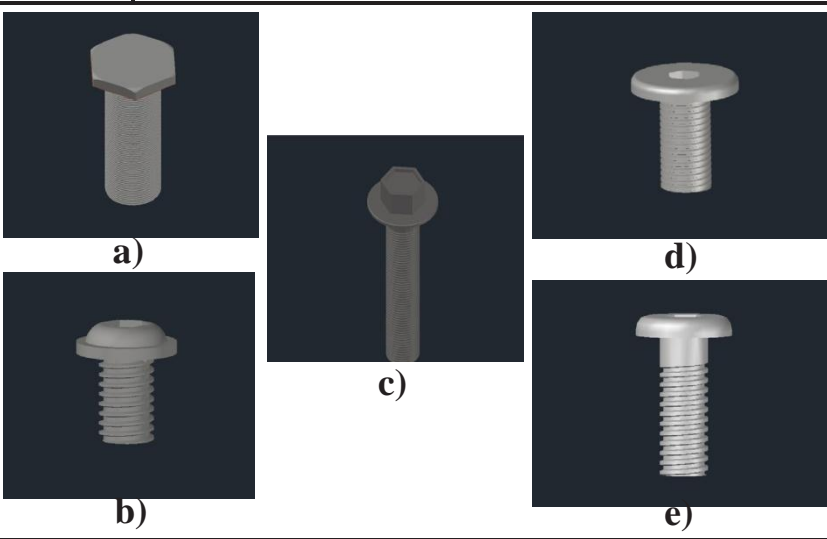
<p>9. Brake – spring for round lid</p>	
<p>10. Cap for circular lid carrier</p>	
<p>11. Plug and seal of container drain plug</p>	
<p>12. Pad for circular carrier</p>	
<p>13. a) Wheel without brake (left) b) Wheel with brake (right)</p>	
<p>14. Rubber carrier - L profile</p>	
<p>15. Screws: a) M8.8 x 65 mm b) 6 x 15 mm c) 10 x 40 mm d) 7 x 20 mm e) 7 x 30 mm</p>	

2. Assembly process

Legend:

Step mark	
Element mark	

2.1 Assembly of wheels

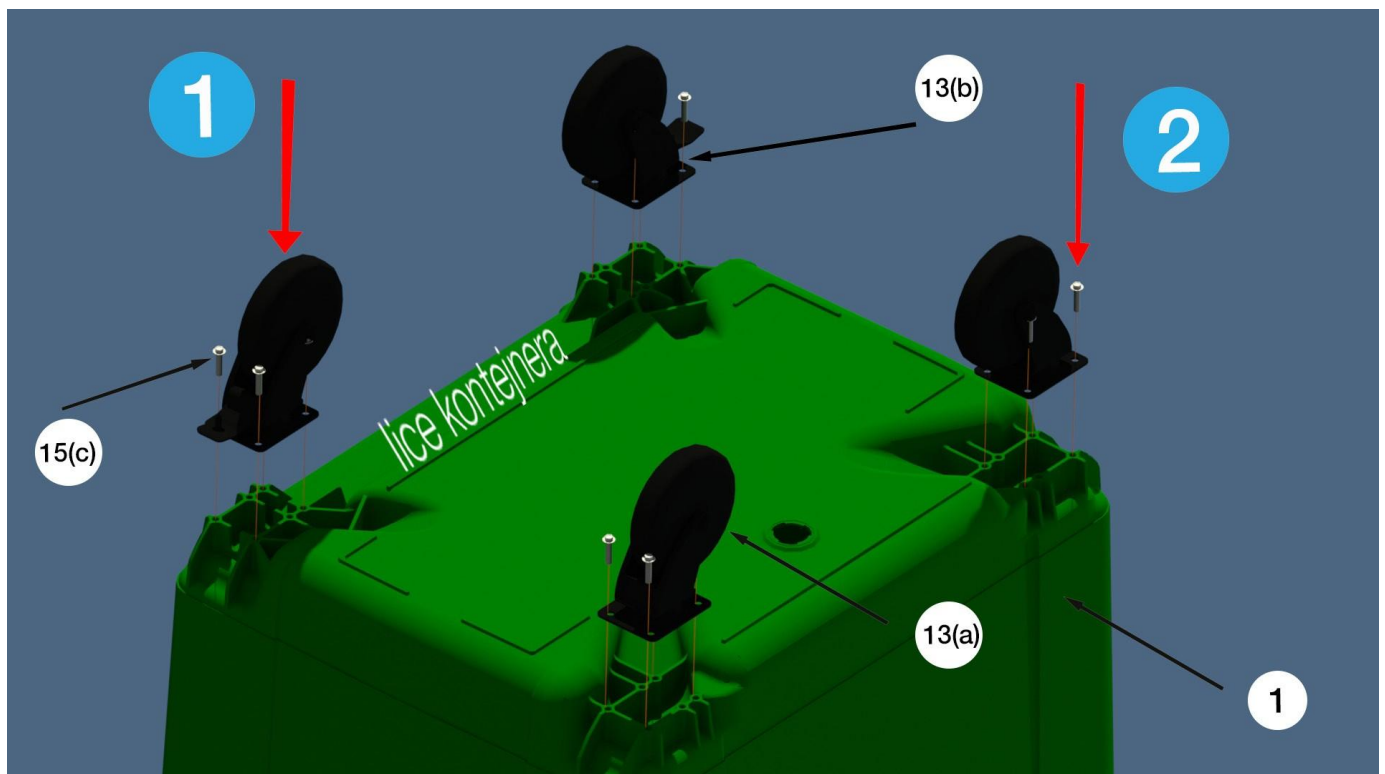

Steps :

Step 1 - Place the wheels (pos.1) on the gripping positions on the body of the container. Wheels with brakes (4b) are mounted on front the side of the container, wheels without brake (4a) are mounted on the back side of the body.

Step 2 - Attach the wheels with screws (15 image C) on the four foreseen positions at each wheel (pos.2)

2.2 Assembly of plug and seal

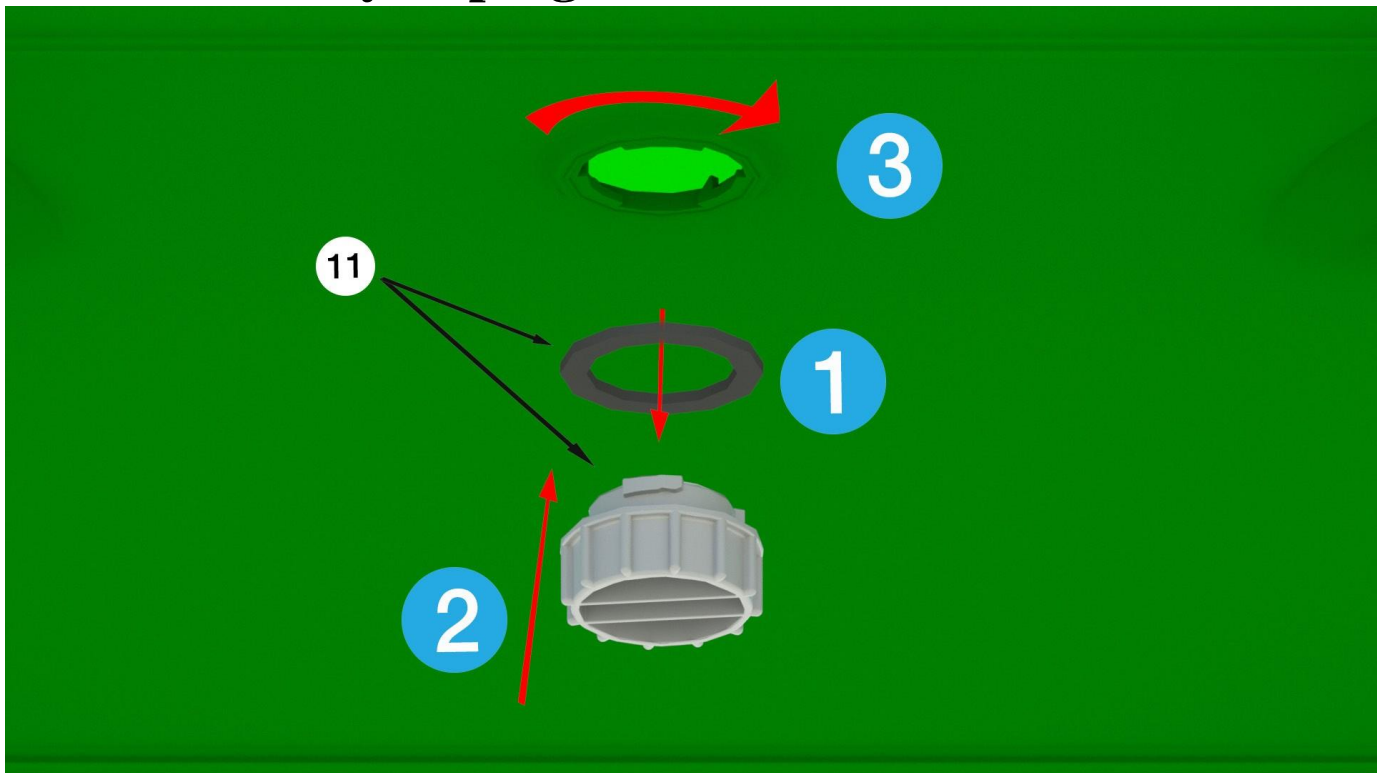

Steps :

Step1 - Place the seal (pos.1) on the container cap.

Step 2 - Put the fused part into the body of the container (pos.2).

Step 3 - Turn the part in the direction of the arrow in the picture (pos. 3).

2.3. Assembly of lifting turnnion

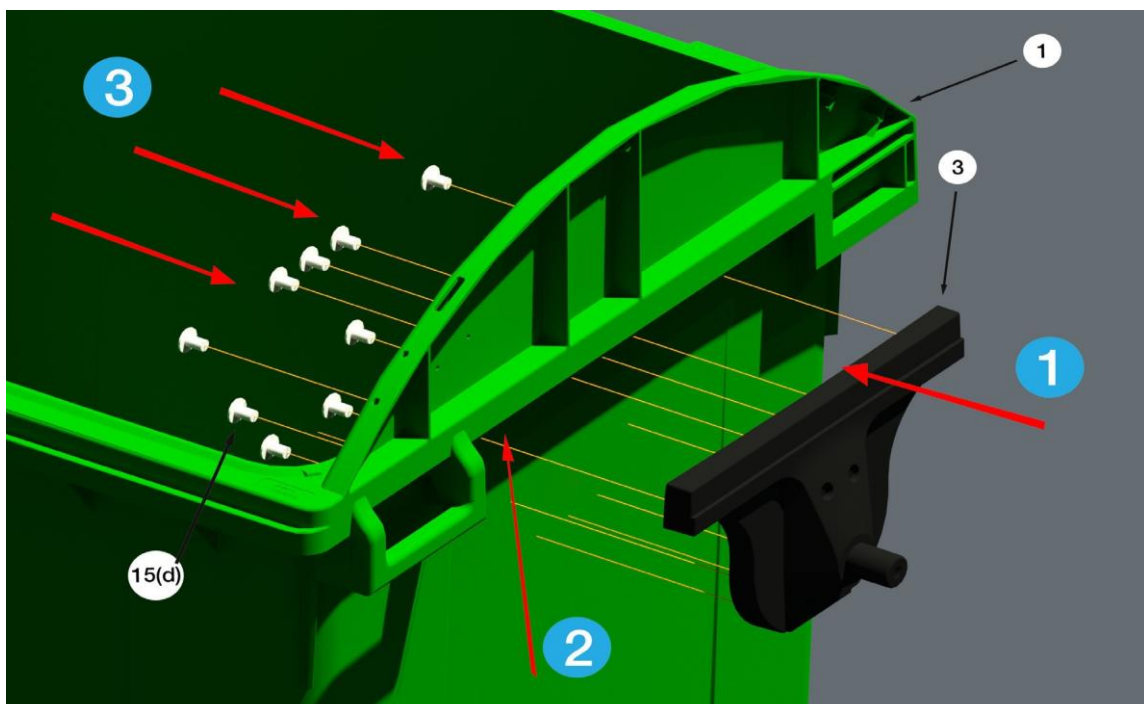

Steps:

Step 1 - Place the lifting turnnion on container body (pos.1).

Step 2 - On foreseen place on container body insert turnnion upwards (pos.2)

Step 3 - Using screw attach lifting turnnion into previously drilled holes on the body of the container (15 image D)

2.4 Assembly of circular lid carrier

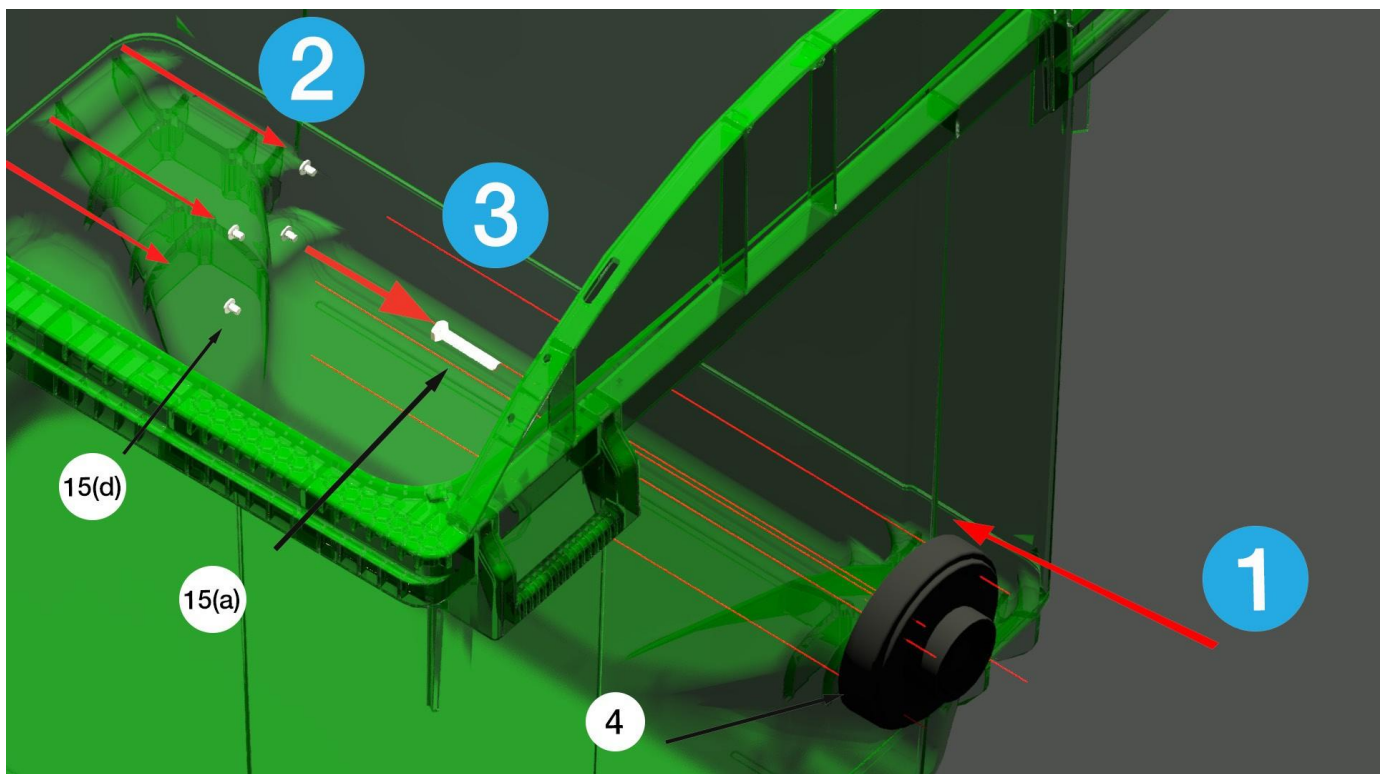

Steps :

Step 1 - Place the carrier in foreseen holes on container and the two circles on the carrier are to be placed on openings in container body (pos. 1)

Step 2 - Then seal 4 screws on openings on container body (15 image d, pos 2)

Step 3 - Attach the screw to a larger hole (15 image a, pos 3)

2.4.1. Assembly of spring on circular carrier

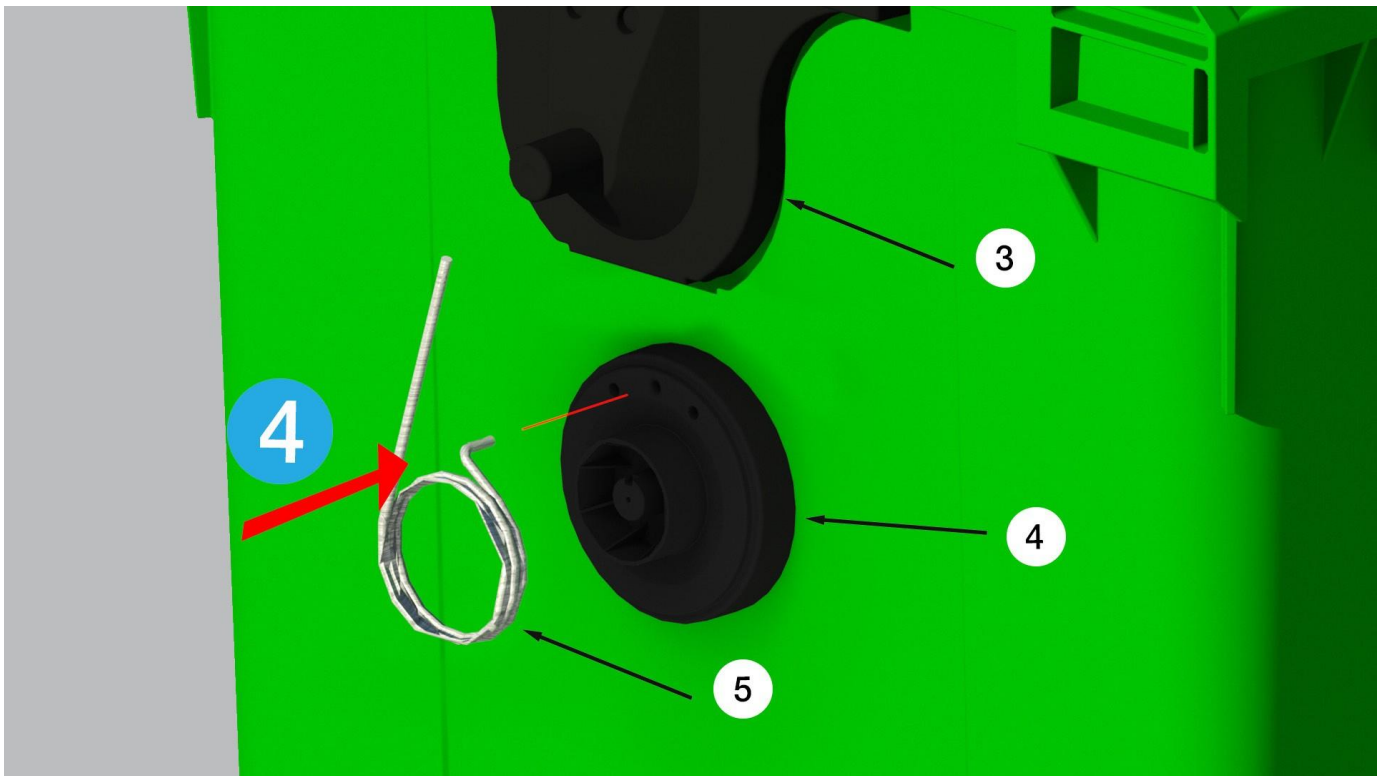

Step 4 - Place the spring on Oprugu postavite u središnji otvor na kružnom nosaču (poz.5).

Assembly of round lid

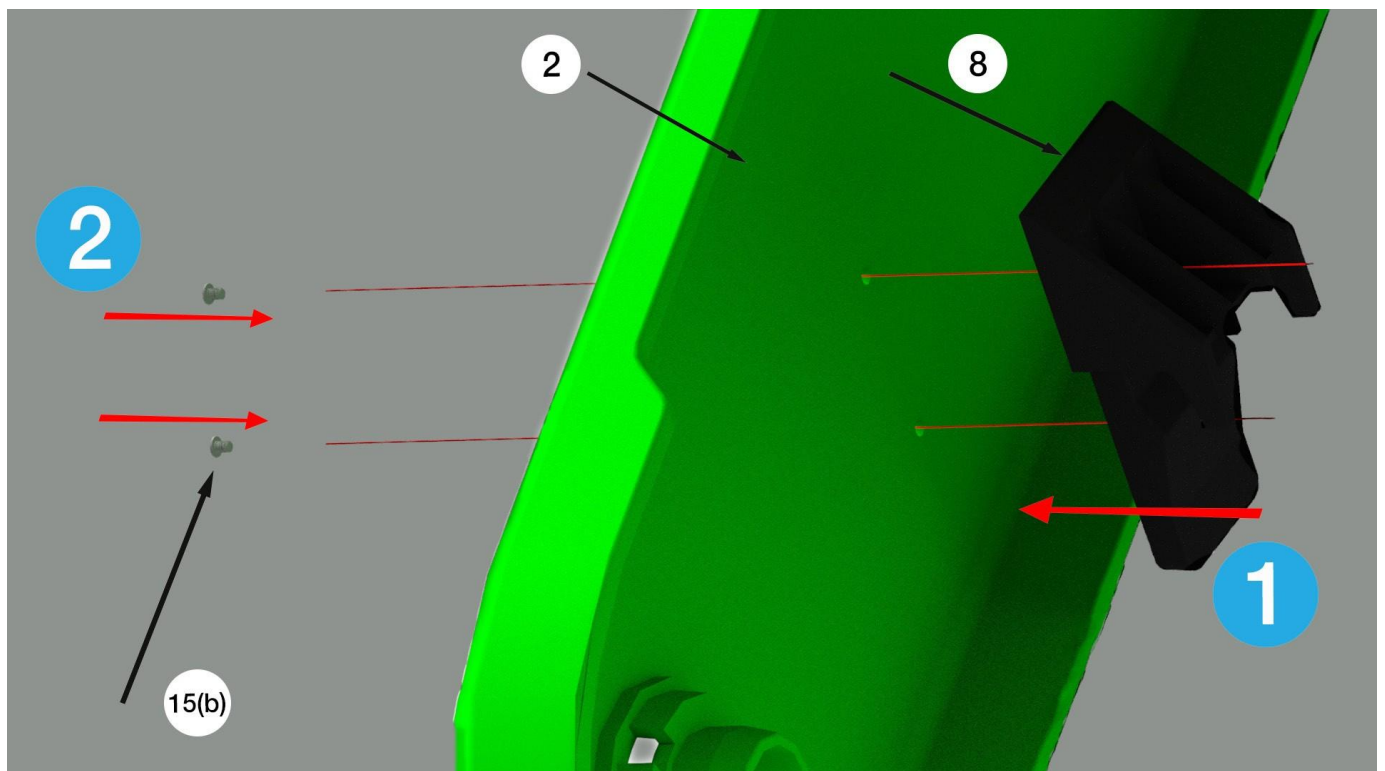

Steps :

Step 1 – Put the comb on existing holes on the round lid (position 1).

Step 2 – Attach the comb with screws (15 picture b.) position 2.

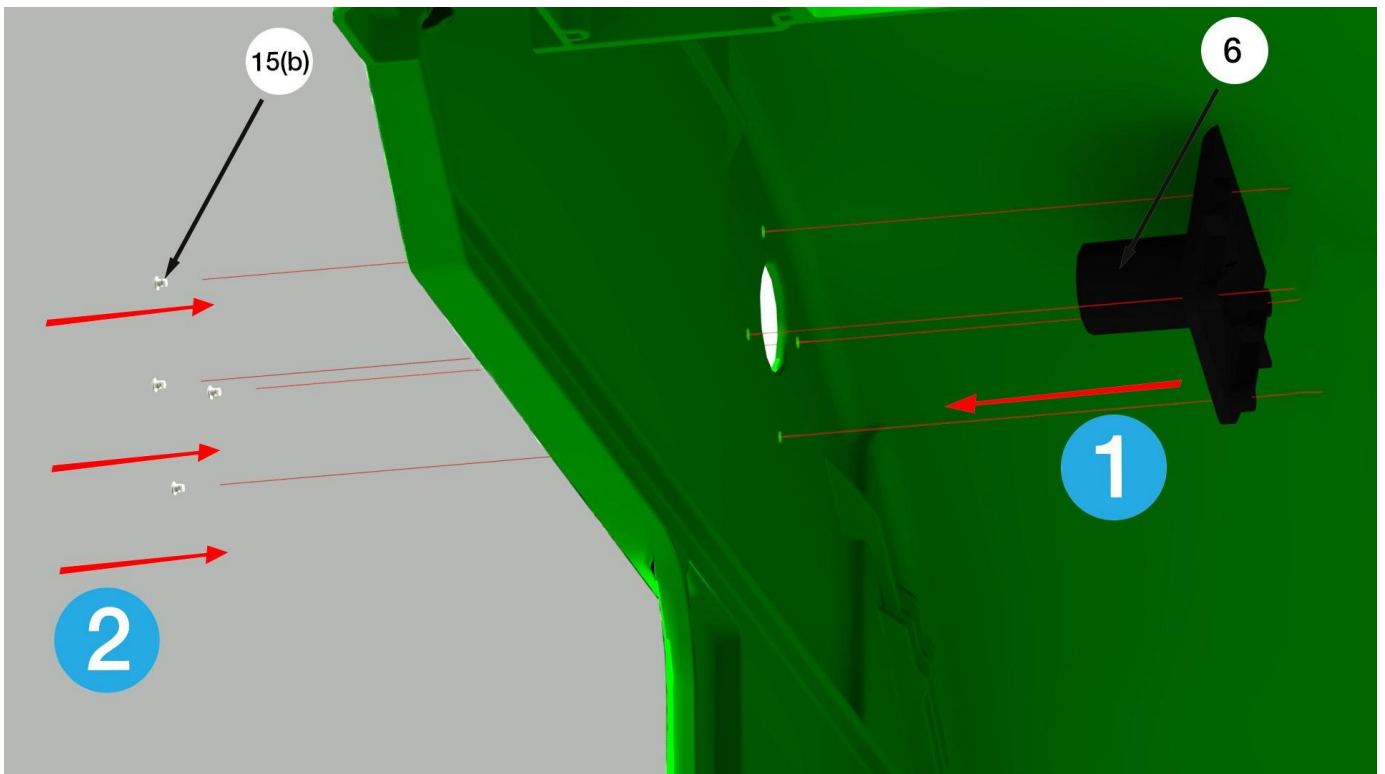

Steps :

Step1 - Put the handle of round lid container in the provided hole on the round lid. (position 1).

Step 2 - Attach the handle with screws (15 picture b.) poz.2.

After complete assembled round lid put the lid on body of container.

Assembling of elements after putting lid

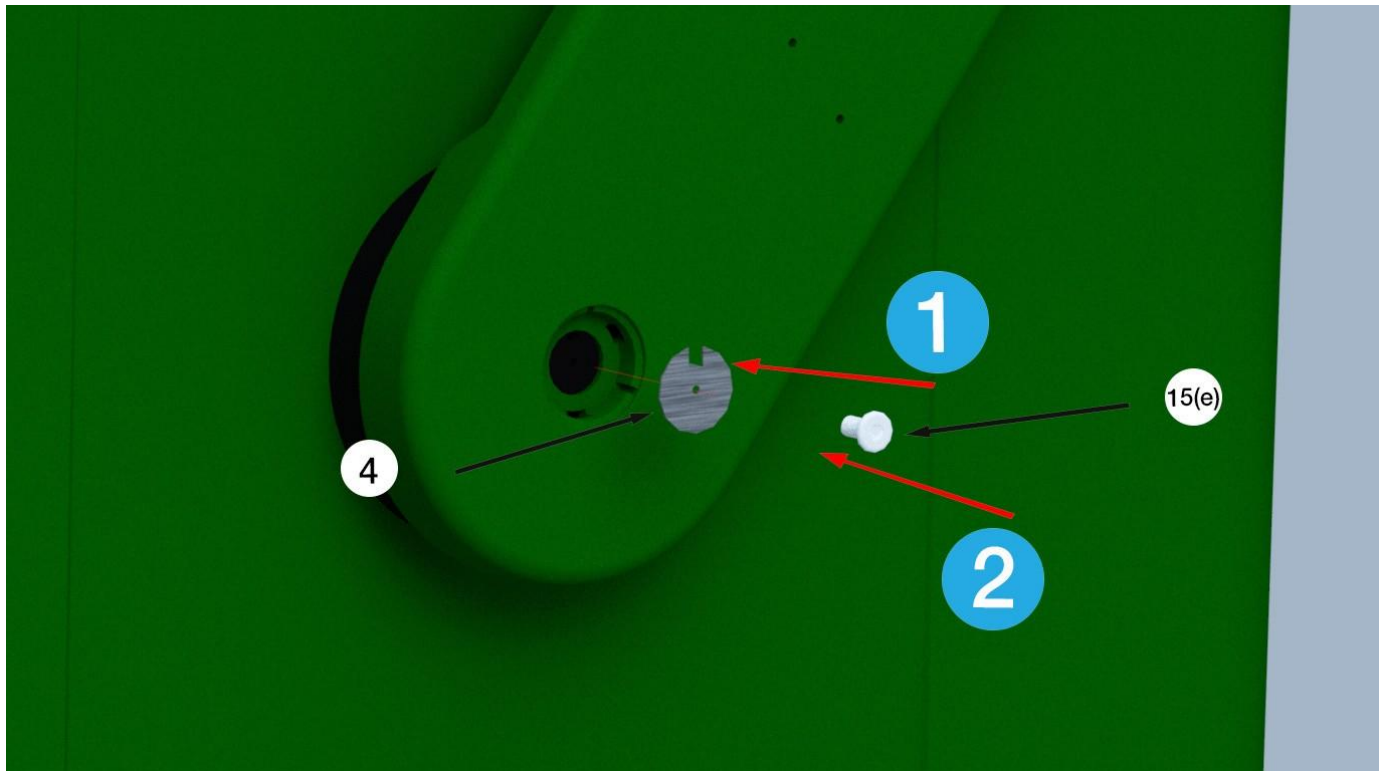

Steps :

Step1 – Put a pad according to the intended position inside the cover of lid. (position 1).

Step 2 - Attach a pad with screw (15 picture e.) position 2 .

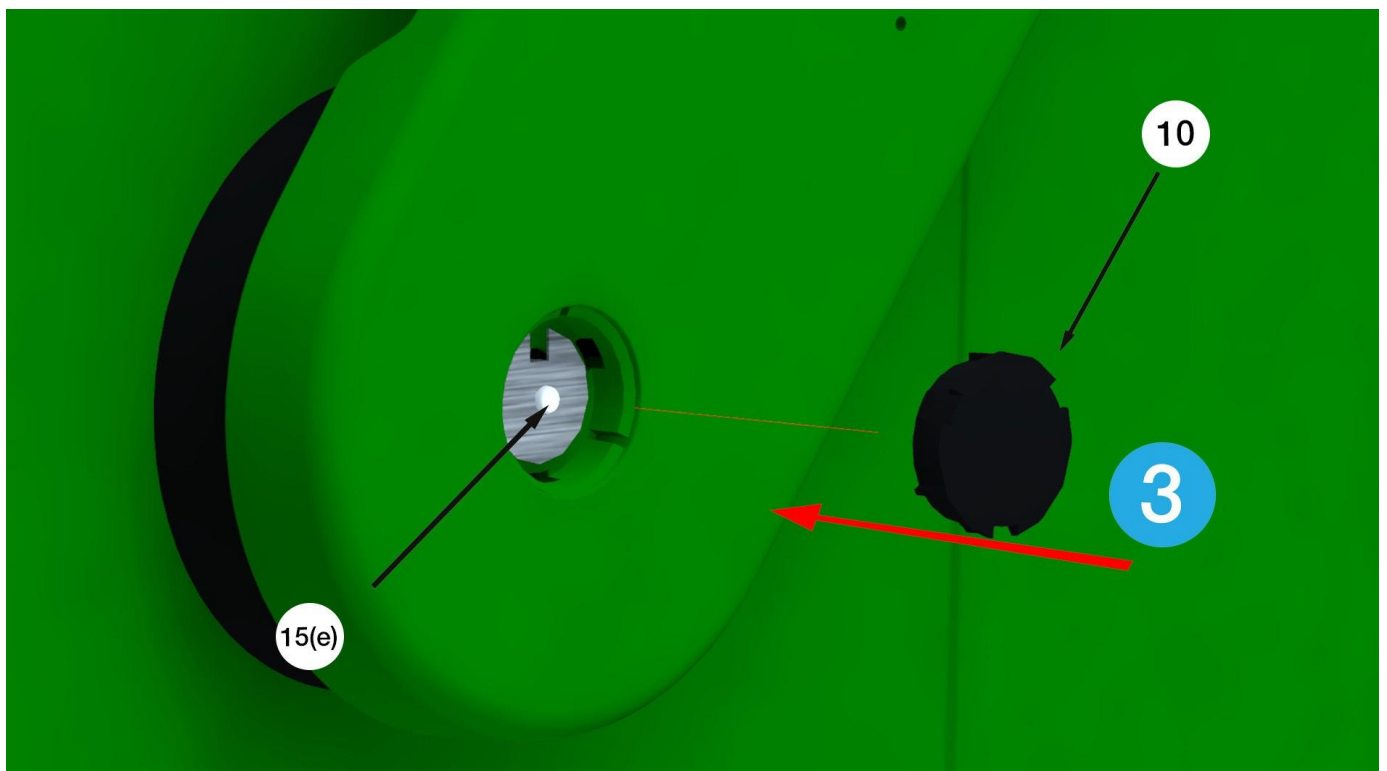

Step 3 – Put the cork on the hole of the lid (position .3).